

[CONTRIBUTION FROM THE CHEMISTRY DEPARTMENT OF DUKE UNIVERSITY]

**Condensations. XII. A General Theory for Certain Carbon-Carbon Condensations Effected by Acidic and Basic Reagents<sup>1</sup>**BY CHARLES R. HAUSER AND DAVID S. BRESLOW<sup>2</sup>

In the previous paper<sup>3</sup> of this series it was shown that the alkylation of a reactive methylenic compound as well as the Claisen, "aldol" (Perkin and Knoevenagel reactions) and Michael types of condensation may be effected by acidic reagents (including boron trifluoride and aluminum chloride) as well as by bases. The purpose of this paper is to discuss a general theory for these condensations.

The four types of condensations mentioned above may be represented, without regard to their mechanisms, in the following manner:

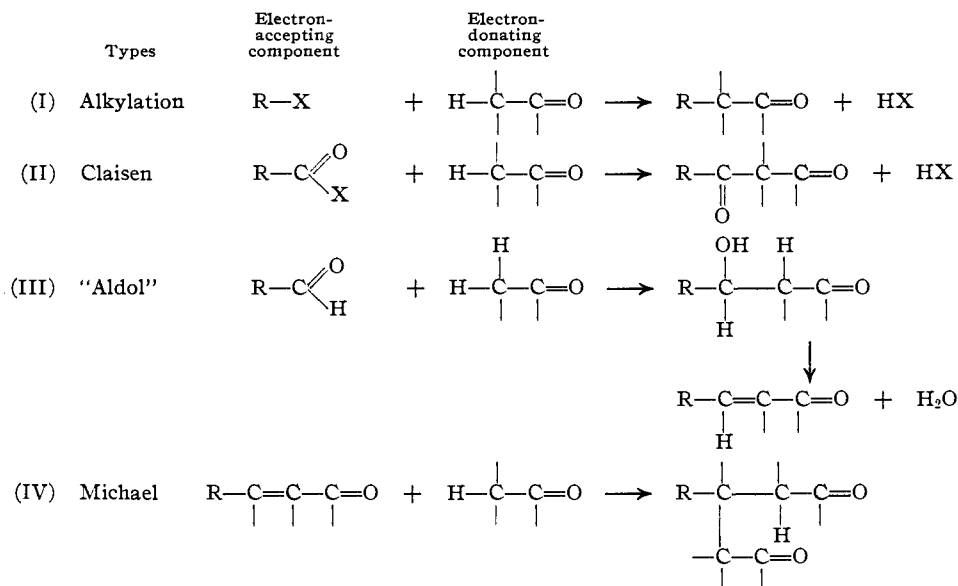

These types of reaction involve the condensation of active hydrogen compounds (electron-donating component) with various electron-accepting components, with or without the elimination of HX. In the alkylation reaction R-X is usually an alkyl halide and the electron-donating component is generally a reactive methylenic compound, such as ethyl acetoacetate. Although the alkylation is commonly effected

by a base (for example, ethyl acetoacetate with sodium ethoxide gives the sodium enolate, which is alkylated), the benzylation of ethyl acetoacetate has been effected by means of boron trifluoride.<sup>3</sup>

In the Claisen type<sup>4</sup> of condensation  $R-\begin{array}{c} O \\ // \\ C \\ \backslash \\ X \end{array}$  is generally an ester, anhydride or acid chloride, where X is OR, OCOR and Cl, respectively. The electron-donating component is usually an ester or ketone. This type of condensation is sometimes considered as an "aldol" reaction, but

we prefer to regard it as a distinct type of condensation. While the Claisen condensation is commonly effected by bases, it has been shown that an analog of this reaction (using acetic anhydride as the electron-accepting and acetophenone as the electron-donating component) has been effected by means of boron trifluoride.<sup>3</sup> It should be pointed out that similar to the Friedel-Crafts reaction, esters alkylate rather than acylate active hydrogen compounds in the presence of boron trifluoride.<sup>5</sup>

The third type of condensation represented above, designated as the "aldol," includes the

(1) This paper was presented before the Division of Organic Chemistry at the Cincinnati meeting of the American Chemical Society, April, 1940.

(2) This paper embodies a part of the material presented by David S. Breslow to the Graduate School of Duke University in partial fulfillment of the requirements for the degree of Doctor of Philosophy, June, 1940.

(3) XI, Breslow and Hauser, *THIS JOURNAL*, **62**, 2385 (1940).

(4) Hauser, *ibid.*, **60**, 1957 (1938).

(5) The details of this reaction will be published in a later paper.

Perkin and Knoevenagel reactions. In this type of condensation the electron-accepting component is generally an aldehyde (but may be a ketone) and the electron-donating component may be an anhydride, ester,  $\beta$ -keto ester, etc. The primary product is undoubtedly a  $\beta$ -hydroxy compound, which may or may not eliminate water. Acidic as well as basic reagents have been used frequently to effect this type of condensation.<sup>3</sup>

In the Michael type of condensation the electron-accepting component is generally an  $\alpha,\beta$ -unsaturated ketone or ester, and the electron-donating component usually an active methylenic compound, such as acetoacetic or malonic ester. Although commonly produced by bases, two examples of this type of condensation have been effected by means of boron trifluoride or aluminum chloride.<sup>3</sup>

Since examples of these four important types of condensation are known in which the reaction is effected either by acidic or by basic reagents, it seems worth while to develop a general theory for these processes. Although the reactivities of both components should be considered in any complete mechanism, it is convenient to focus attention on the activation of one component at a time. As a working hypothesis it is assumed that in condensations effected by bases, the electron-donating component, an active hydrogen compound, is activated, whereas in condensations effected by acidic reagents, the electron-accepting component is activated. The mechanism of activation of the active hydrogen compound involves its reaction with a base to form its enolate anion, as has been discussed previously for the Claisen,<sup>4</sup> Perkin<sup>6</sup> and Michael<sup>7</sup> types of condensations; thus<sup>8</sup>

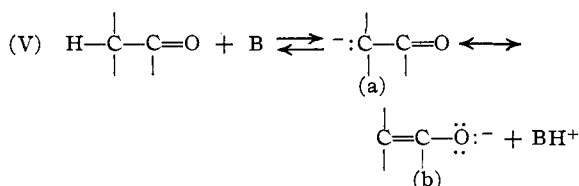

The enolate anion thus formed serves as the "active" electron-donating component in these reactions, the anion apparently acquiring the structure of resonance form (a) as it approaches the electron-accepting component in the reaction.

(6) Hauser and Breslow, *THIS JOURNAL*, **61**, 793 (1939).

(7) Hauser and Abramovitch, *ibid.*, **62**, 1763 (1940).

(8) The double-headed arrow is used to illustrate resonance forms. See especially Hammett, "Physical Organic Chemistry," McGraw-Hill Book Co., New York, N. Y., 1940.

The mechanism of activation of the electron-accepting component by means of an acidic reagent is considered to involve the formation of a coordination complex as has been assumed by Price,<sup>9</sup> Snyder,<sup>10</sup> Arndt and Eistert<sup>11</sup> and others in the Friedel-Crafts and certain other types of reaction. The tendency for ionization (or electron-shift) in the electron-accepting component should be facilitated by the formation of a coordination complex with an acidic reagent; this may be indicated by the following formulas, in which the curved arrows represent the tendency for ionization and the straight arrows represent the formation of the coordination complex.

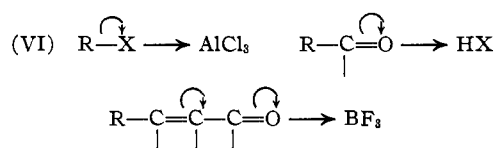

These changes indicate the formation of carbonium ions as the "active" electron-accepting component. Thus, the carbon-carbon condensations represented above may be considered to involve reactions between carbanions (from the electron-donating component) and carbonium ions (from the electron-accepting component), although these ions may have only transient or no "actual" existence.

It should be pointed out that a base may attack not only the active hydrogen compound to give the corresponding anion, but may attack the electron-accepting component as well; however, such a process would not favor the carbon-carbon condensation. For example, a base such as sodium ethoxide may attack an alkyl halide or a carbonyl group, but this reaction merely competes with the carbon-carbon condensation of the carbanion (formed by the action of the base on the active hydrogen compound) with the electron-accepting alkyl halide or carbonyl group. Moreover, an acidic reagent (especially boron trifluoride) may attack not only the electron-accepting component but also the active hydrogen compound at the carbonyl end of the molecule, thus

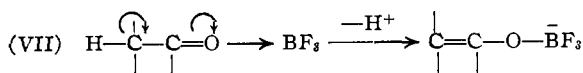

This attack should facilitate the ionization of a proton (which is taken up by a proton acceptor

(9) Price and Ciskowski, *THIS JOURNAL*, **60**, 2499 (1938).

(10) Snyder, Kornberg and Romig, *ibid.*, **61**, 3556 (1939).

(11) Arndt and Eistert, *Ber.*, **69**, 2387 (1936).

in the medium), but because of the strongly electron-attracting nature of the boron trifluoride the process apparently does not lead to the formation of a carbanion (with the negative charge on the carbon atom).<sup>12</sup>

On the basis of the ideas discussed above one should expect that in the presence of acidic reagents condensation would take place only when the electron-donating component possesses sufficient reactivity of its own (that is, will ionize a proton sufficiently readily), and that with a particular electron-accepting component and various electron-donating components, the ease of condensation will increase as the reactivity of the latter increases. This has been verified using benzaldehyde as the electron-accepting component and the following series of electron-donating components, which are arranged in the order of increasing activities of the ionizable hydrogen atom:

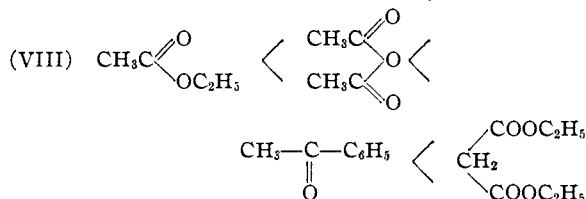

In the presence of boron trifluoride under comparable conditions, ethyl acetate fails to condense with benzaldehyde, acetic anhydride condenses with benzaldehyde to give a small yield of cinnamic acid, acetophenone and ethyl malonate condense with benzaldehyde to give good yields of benzalacetophenone and ethyl benzalmalonate, respectively, the latter then undergoing a Michael condensation with unchanged ethyl malonate.

In this connection should be considered the results of Snyder, Kornberg and Romig,<sup>10</sup> who showed that in the presence of boron trifluoride certain methyl ketones react with benzalaniline to give solid addition products. The reaction, which is an analog of the aldolization reaction, may be represented as follows

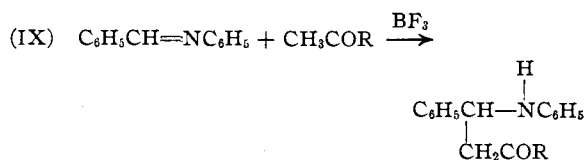

(12) It is possible that because of the enolizing action, certain acidic reagents may activate the electron-donating component to some extent.

Certain compounds which are less reactive than the methyl ketones, for example, ethyl acetate, failed to give solid products. Although certain others which are more reactive, for example, ethyl cyanoacetate or ethyl acetoacetate, also failed to give solid products, we believe that these results are not irreconcilable with the ideas discussed above. Similar to our results with benzaldehyde, ethyl acetate is apparently too unreactive to condense with benzalaniline, while ethyl cyanoacetate condenses with benzalaniline to give ethyl benzalcyanoacetate. This product, which was formed presumably by the elimination of aniline from the addition compound, was isolated by Snyder and co-workers. Ethyl acetoacetate adds to benzalaniline even in the absence of boron trifluoride, but the addition product is unstable.<sup>13</sup> In the presence of boron trifluoride the addition compound decomposes, but it is not clear what products are formed. Another reactive methylenic compound, ethyl malonate, reacts with benzalaniline in the presence of boron trifluoride to give a fair yield (27%) of the addition product.

Again, on the basis of the ideas discussed above, one might expect that certain compounds, ethers for example, which are not sufficiently reactive to serve as the electron-accepting component in the presence of a base, might nevertheless be capable of serving as this component if activated by an acidic reagent; this has been realized. In the presence of boron trifluoride, isopropyl ether condenses with ethyl acetoacetate to give a good yield (70%) of ethyl  $\alpha$ -isopropylacetoacetate. Also, isopropyl alcohol condenses with ethyl acetoacetate in the presence of boron trifluoride. These reactions may be represented as follows

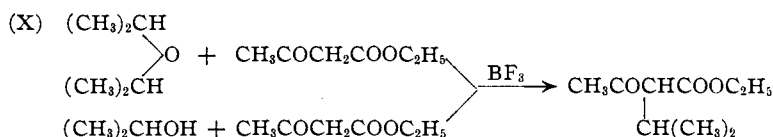

### Experimental

**Condensation of Benzalaniline with Ethyl Malonate.**—To a solution of 3.6 g. (0.02 mole) of benzalaniline (m. p. 51.5–52.0°<sup>14</sup>) and 3.2 g. (0.02 mole) of purified<sup>9</sup> ethyl malonate was added 4 cc. of Eastman Kodak Co. boron trifluoride etherate essentially as described by Snyder and co-workers.<sup>10</sup> The reaction mixture was poured into 100 cc. of ice and water after standing in an ice-bath for five minutes. The oil first formed rapidly solidified and was filtered off. The precipitate was recrystallized several

(13) Francis, *Ber.*, **36**, 938 (1903).

(14) Bigelow and Eatough, "Organic Syntheses," Collective Volume I, John Wiley and Sons, New York, N. Y., 1932, p. 73.

times from methanol-water mixtures; in this way 1.6 g. of ethyl  $\alpha$ -( $\alpha$ -anilinobenzyl)-malonate was obtained, m. p. 98–99°,<sup>10</sup> and in addition a small fraction (0.2 g.) melting at 94–96°. The total yield of addition product was 1.8 g. (26.5% of the theoretical amount). No benzalaniline was recovered.

**Condensation of Benzalaniline with Ethyl Acetoacetate.**—Benzalaniline was condensed with purified<sup>3</sup> ethyl acetoacetate according to the method of Schiff.<sup>15</sup> Since the compound formed, ethyl  $\alpha$ -( $\alpha$ -anilinobenzyl)-acetoacetate, exists in two forms and is unstable,<sup>18</sup> it was not recrystallized but was washed three times with cold benzene to remove unreacted materials and dried on a porous plate; m. p. 92–95°. Schiff reported the melting point as 93–95°, but Francis<sup>13</sup> showed this to be a mixture of two forms, one melting at 108° and the other at 80°.

On treating a suspension of this compound in ether with boron trifluoride, decomposition occurred at room temperature. Benzaldehyde was recovered as the phenylhydrazone (m. p. 156–157°, literature m. p. 158°<sup>16</sup>) in 63% yield. The presence of ethyl acetoacetate was indicated by a positive ferric chloride test.

In a similar experiment using acetone as a solvent, no benzaldehyde could be isolated. The presence of ethyl acetoacetate was again indicated by a positive ferric chloride test. Aniline was isolated as acetanilide, m. p. 114–114.5° (melting point in the literature<sup>17</sup> 114°). A small amount of solid was obtained which was presumably ethyl benzalacetoacetate, but not enough was obtained for identification.

**Alkylation of Ethyl Acetoacetate with Isopropyl Ether.**—A solution of 26.0 g. (0.20 mole) of purified ethyl acetoacetate and 20.4 g. (0.20 mole) of isopropyl ether (distilled over sodium, b. p. 68.5–69.0°) was saturated with boron trifluoride as previously described,<sup>3</sup> 32.0 g. (0.47 mole) of boron trifluoride being taken up by the solution. The cloudy yellow solution formed was allowed to stand at room temperature for seventeen hours and was then hydrolyzed with 70 g. of anhydrous sodium acetate in 200 cc. of water. The hydrolyzed solution was extracted with several portions of ether and the combined ether solutions dried over "Drierite."

The dried ethereal solution was distilled through a short Widmer column. The ether was distilled off and then acetic acid taken off up to 116°. The next fraction started to distill at 202°, showing the absence of ethyl acetoacetate (b. p. 181°<sup>18</sup>). The fraction was collected at 202–204°, 24.4 g. of essentially pure ethyl  $\alpha$ -isopropylacetoacetate

being obtained. The boiling point of this compound is recorded<sup>19</sup> as being 202–203°. A deep red residue (8.2 g.) was obtained, which would not distill at a bath temperature of 360°, showing that it probably was not ethyl  $\alpha$ , $\alpha$ -diisopropylacetoacetate.

The ethyl  $\alpha$ -isopropylacetoacetate was identified by hydrolysis to methyl isobutyl ketone. A portion (10 g.) of the distillate was refluxed for six hours with a solution consisting of 20 cc. of glacial acetic acid, 2.5 cc. of concentrated sulfuric acid and 2.5 cc. of water. The clear solution was diluted with water and saturated with sodium carbonate. The alkaline solution was extracted with several portions of ether, the combined ether solutions dried, the ether carefully distilled off and the residue collected at 111–116° (the boiling point of methyl isobutyl ketone is listed in the literature<sup>20</sup> as 119°). The distillate was identified as methyl isobutyl ketone by its semicarbazone, m. p. 134.0–134.5°.<sup>20</sup>

The yield of ethyl  $\alpha$ -isopropylacetoacetate was 70.9% of the theoretical amount based on the ethyl acetoacetate.

**Alkylation of Ethyl Acetoacetate with Isopropyl Alcohol.**—A solution of 26.0 g. (0.20 mole) of ethyl acetoacetate and 24.0 g. (0.40 mole) of isopropyl alcohol (dried over "Drierite," b. p. 82.1–82.2°) was saturated with boron trifluoride, 39.0 g. (0.58 mole) being absorbed. The reaction mixture was yellow and gradually separated into two layers on standing. It was stirred at room temperature for twenty hours and then hydrolyzed with sodium acetate solution. The hydrolyzed solution was treated as described in the preceding experiment, 13.9 g. (40.4% of the theoretical amount based on ethyl acetoacetate) of ethyl  $\alpha$ -isopropylacetoacetate, boiling at 198–202°, being obtained. It was identified by hydrolysis to methyl isobutyl ketone as described in the preceding experiment.

## Summary

A general theory for certain carbon-carbon condensations effected by acidic or basic reagents is discussed. Experimental results in support of the theory are presented.

Ethyl acetoacetate has been successfully alkylated both by isopropyl ether and isopropyl alcohol in the presence of boron trifluoride.

The reaction of benzalaniline with certain methylenic compounds in the presence of boron trifluoride has been studied.

DURHAM, NORTH CAROLINA RECEIVED JUNE 28, 1940

(15) Schiff, *Ber.*, **31**, 207 (1898).

(16) Shriner and Fuson, "Systematic Identification of Organic Compounds," John Wiley and Sons, New York, N. Y., 1935, p. 110.

(17) *Ibid.*, p. 119.

(18) *Ibid.*, p. 103.

(19) Skita and Ritter, *Ber.*, **43**, 3396 (1910).

(20) See Ref. 16, p. 109.